

Aseptic Pharmaceutical Processing Equipment

Uniquely engineered to outperform



SPScientific.com/PennTech

Semi-Automatic Vial Washing: Model RW-250



Uniquely engineered with versatility and efficiency in mind.

- Vial range: 2-100ml
- Output: up to 70 vpm
- Compact footprint: 127x114cm
- GMP design: All 304/316L stainless steel

Today's aseptic processing requires flexibility. That's why our vial washers are designed to cover the full range of pharmaceutical vials, from 2-100ml, both glass and plastic. The RW-250 is specifically designed for compounding pharmacies, clinical studies, contract manufacturing organizations, and startup companies for batches of 100-6,000 vials. If no WFI-loop is available, a self-contained WFI-skid is available to supply the WFI at 80°C.

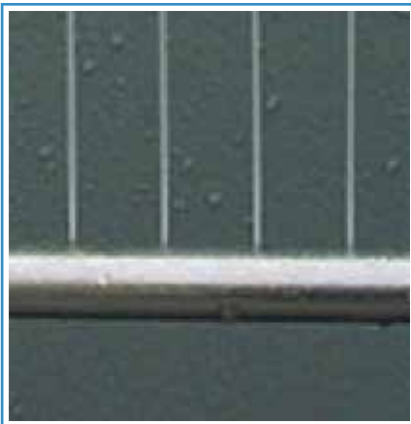
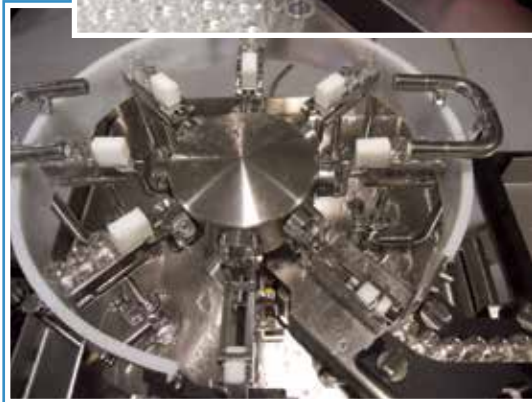

Advantages:

- 15-minute changeover to a different vial format
- No penetrating nozzles, no glass breakage, less particulate generation
- Self-draining after end of batch
- Optional WFI-skid (no need for a WFI-loop)
- Complete validation documents package available (FRS, DDS, FAT/SAT, IQ/OQ)

Low-to-Medium Output Vial Washing: Model RW-500

The objective of vial washing is to remove particulate matter and microorganisms. Traditional vial washers have many moving parts (grippers with springs, penetrating spray needles, chains, and moving rods) in the washing chamber, all of which, generate particulate matter.

SP Scientific's PennTech washers have only two moving parts in their washing chamber and their main drive is servo-driven.

Each vial format has an HMI selected "recipe" with specific settings for spray time and indexing time to help reduce water consumption.

Water for injection (WFI) can be recycled, filtered and used a second time, further reducing water consumption. These factors result in a highly efficient vial washing process.

For almost 25 years, PennTech has optimized and perfected the art of vial washing. In doing so, their equipment has a very small footprint, making them easy to maintain, changeover, and operate.



- Vial range: 1-100ml
- Output: up to 120 vials per minute
- Compact footprint: 133x128cm



Medium- and High-Speed Vial Washing: Models RW-800/RW-1150



cGMP Design:

- All stainless steel construction
- Internally electropolished piping
- Sanitary connections
- Orbital welds
- Sloped piping to prevent water stagnation
- Automatic draining at the end of the batch

Simplicity:

- Menu-driven operation
- Programmable logic controller (PLC) assisted changeover in 15 minutes
- Direct servo-motor drive (no belts, no chains, no gears, no moving parts)
- No penetrating nozzles, no glass breakage, no nozzle bending
- Virtually maintenance free

Functionality:

- Intrinsically designed to remove 3-log bacterial endotoxin, up to 500ml bottles (on certain models)
- Low water consumption (as little as 3 liter/min)
- WFI recycling available, intermittent spraying, small footprint, compact design.

"...I just wanted to thank you and the staff at PennTech for an excellent FAT experience. We were VERY pleased!"
PB, New Hampshire

"I would highly suggest the purchase of a PennTech vial washer over the more costly and significantly more complicated European offerings. The PennTech washer is simply the most efficient and effective washer on the market..."
SH, Indiana

"We've had our PennTech RW-800 for almost 2 years now and we are very pleased; it works flawlessly. We purchased the machine because we had problems with vial breakage on the existing equipment. This problem was eliminated with the RW-800; it has not crushed a single vial..."
JOS, Denmark

Vials			Output (vials/min)			
Size	Ø (mm)	Height (mm)	RW-250	RW-500	RW-800	RW-1150
2R	16.0	35,0	70	120	240	340
4R	16.0	45,0	70	120	240	340
5H	20.8	41,3	50-60	80	180	260
6R	22.0	40,0	50-60	80	180	240
8R	22.0	45,0	50-60	80	180	240
7H	22.1	40,8	50-60	80	180	240
8H	23.0	46,8	50-60	80	160	220
10R	24.0	45,0	50-60	80	160	220
15R	24.0	60,0	50-60	80	160	220
10H	25.4	53,5	40-50	60	160	220
15H	26.5	58,8	40-50	60	140	200
20R	30.0	55,0	40-50	60	120	180
25R	30.0	65,0	40-50	60	120	180
30R	30.0	75,0	40-50	60	120	160
20H	32.0	58,0	40-50	60	120	160
25H	36.0	58,0	30-40	40	100	160
30H	36.0	62,8	30-40	40	100	140
50H	42.5	73,0	30-40	40	80	120
100H	52.6	94,5	20	20	60	120
250H	64.0	150,0	n/a	n/a	40	80
500H	77.5	177,0	n/a	n/a	40	60

Hot Air Sterilizing and Depyrogenation Tunnels

Fast, Flexible, Efficient & Effective

Continuous aseptic processing has significant advantages over batch processing. In fewer than 30 minutes, an untreated vial goes from vial washer to sterilizing tunnel to cleanroom, entering in a sterilized microorganisms- and pyrogen-free state. The process is automatic and requires no operator intervention or recontamination.

A bit of theory:

Heat, over a period of time, destroys microorganisms. The rate of destruction is more or less logarithmic, meaning that during a given time period and at a certain temperature, the same percentage of the bacterial population will be destroyed during the same period. If the time required to destroy 1-log cycle (90%) is known, and the desired thermal reduction has been decided (e.g., 4-log), then the time required can be calculated.

Example: If the bacterial population is 1 million CFUs (Colony-Forming Unit), and it takes 5 minutes to destroy 1-log cycle at a certain temperature, then the remaining population after 5 minutes is 100,000 CFU, after 10 minutes 10,000 CFU, after 15 minutes 1,000 CFU and after 20 minutes 100 CFU (4-log cycles).

At 250°C, the time required to disintegrate pyrogens 1-log cycle is 5 minutes (D-value). Tests have shown that for every 46.4°C increase in temperature, the D-value will be reduced by 1-log cycle. In other words, at a temperature (T) of 296.4°C, a 1-log pyrogen reduction is accomplished after 30 seconds. At a temperature of 342.8°C, a 1-log pyrogen reduction is accomplished after 3 seconds.

	1-log	2-log	3-log	4-log
T=250°C	300 sec.	600 sec.	900 sec.	1200 sec.
T=296.4°C	30 sec.	60 sec.	90 sec.	120 sec.
T=342.8°C	3 sec.	6 sec.	9 sec.	12 sec.



Hot Air Sterilizing and Depyrogenation Tunnels

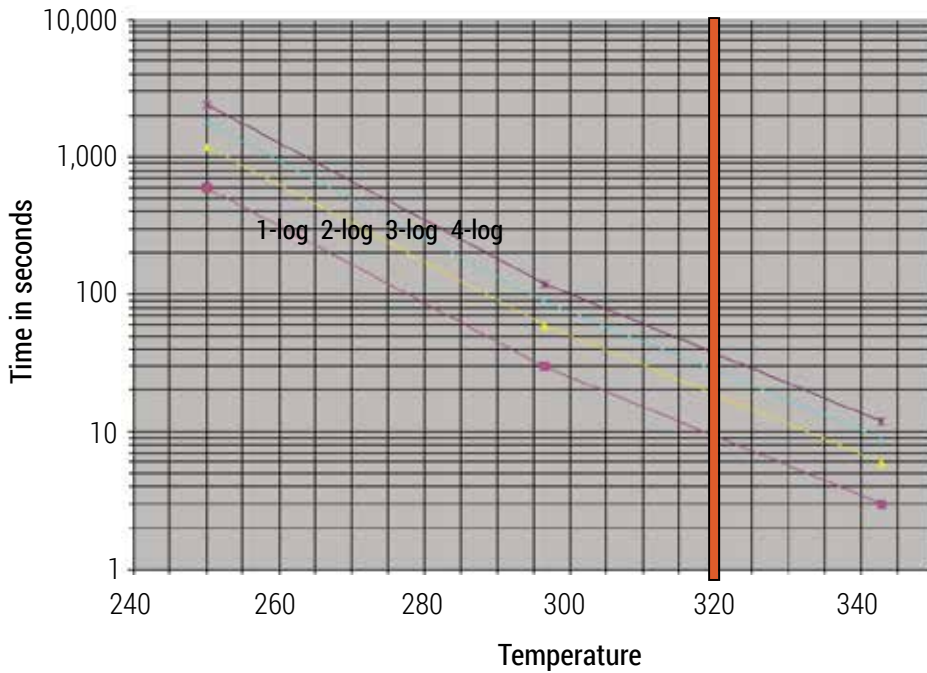

The typical operating temperature of the tunnel is 320°C. At this temperature, it takes 9.5 seconds to reduce the bacterial endotoxin level by 1-log. A 4-log reduction will take 38 seconds, and a 6-log reduction in bacterial endotoxin 57 seconds.

Heat is generated by silicon controlled rectifier (SCR) heating elements. Depending on the format, vials stay inside the sterilizing/depyrogenation chamber for approximately 6-10 minutes. The recirculated hot air is blown at a speed of approximately 0.7 m/s over the vials and remains within 2°C of its setpoint.

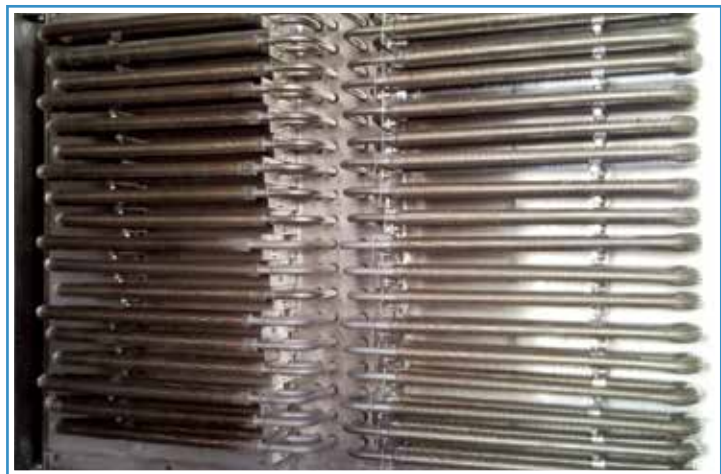

	Output in Vials per Minute											
	2R	5R	10R	15R	20R	30R	5H	10H	20H	30H	50H	100H
PST-30/160	130	68	56	56	35	35	69	37	21	16	11	6
PST-45/240	297	155	128	123	81	65	128	83	49	37	26	14
PST-45/290	330	177	143	127	90	67	148	93	53	40	28	15
PST-45/380	450	250	200	180	130	110	210	130	70	55	35	22
PST-60/420	605	333	260	240	175	140	276	183	108	83	52	28
PST-80/450	780	445	395	383	250	200	400	260	152	114	75	44
PST-120/520	1380	830	700	667	450	433	700	458	267	200	135	76

Hot Air Sterilizing and Depyrogenation Tunnels

SP Scientific's PennTech units offer a uniquely simple, yet effective, method of loading vials into the depyrogenation tunnel.

Keeping control over the vials at all times, vials are fed from the vial washer via a sanitary conveyor before gently being pushed into the tunnel by an oscillating pusher.

No format parts are required. This is essentially a set-it-and-forget-it automatic process requiring no operator intervention.

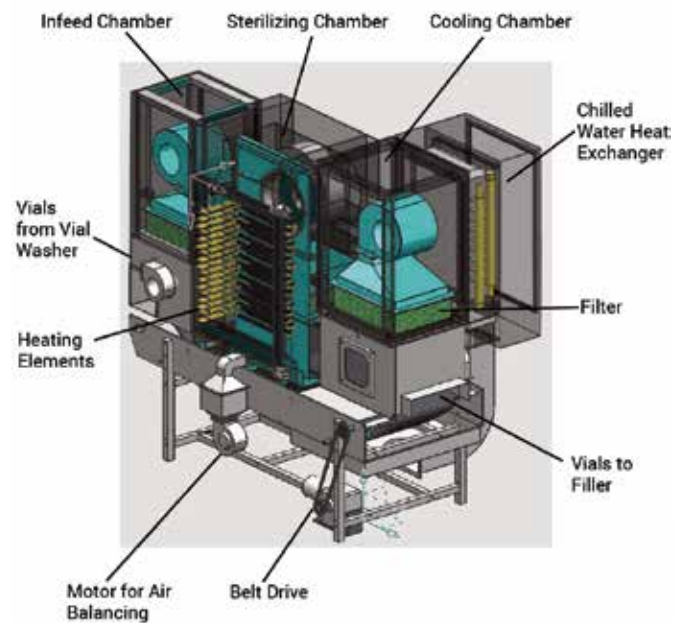
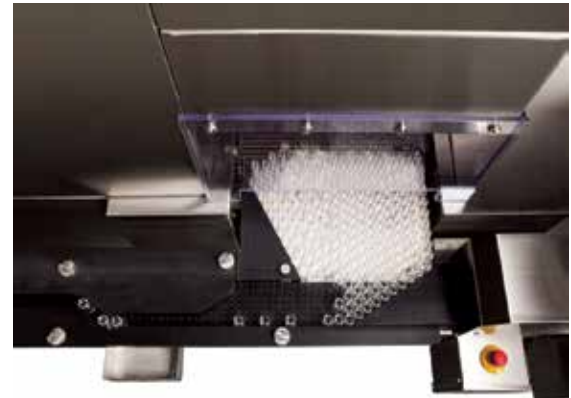

Automatic Gate Height Setting: The three chambers of the tunnel are separated by gates. The height is automatically set by the PLC as part of the vial recipe.

DOP Testing: HEPA filters are tested for efficiency by the "DOP" test procedure. Each chamber of the tunnel has provisions to conduct the DOP test.

Particle Counting: Each chamber is equipped with a pipe below the filters to allow for particle counting.

Sterilizing tunnels are comprised of three chambers:

- The pre-heating chamber
- The sterilizing chamber
- The cooling chamber



Filling and Stopper-Inserting



When it comes to liquid filling, SP Scientific offers a choice of filling machines and dispensing methods.

Depending on your application and output requirement, you can choose between:

Model FSC-1R: a 1-up filling, stoppering and capping system for 2-100ml vials with an output of up to 30 vials per minute.

Model FSC-2: a 2-up filling, stoppering and capping system for 2-100ml vials with an output of up to 60 vials per minute

Model FS-2: a 2-up filling and stoppering machine for 2-100ml vials with an output of up to 100 vials per minute.

Model FS-4: a 4-up filling machine with a vacuum rotary stopper-inserting disk for 2-100ml vials with an output of up to 200 vials per minute.

Peristaltic Pumps: If you're looking for high precision peristaltic pumps, don't look any further. We apply the highest precision and most advanced pumps that are driven by PLC-controlled individual servo motors. The rollers are positively driven, substantially increasing the longevity of the tubing, hence maintaining the fill accuracy. Drip-free filling is an inherent feature. Gamma sterilized, disposable filling systems are available, rendering cleaning and sterilizing superfluous, while preventing cross contamination.

Rotary Piston Pumps: Our PennTech rotary piston pumps are constructed from a single piece of 316 stainless steel. High precision seal-less and hard-coated matching sets provide high accuracy and repeatability throughout the entire batch.

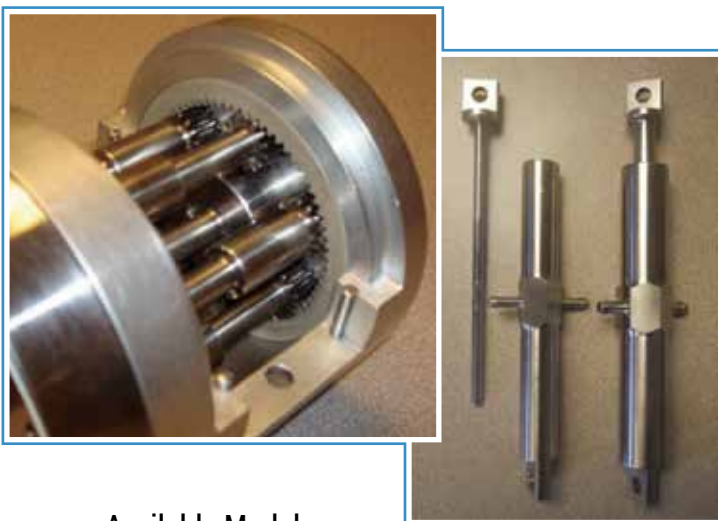

Available Models:

	From	To
RPP-1	0.05	1.5 ml
RPP-10	1.0	10.5 ml
RPP-50	5.0	51.0 ml
RPP-100	50.0	102.0 ml

Filling, Stopper-Inserting and Capping



Courtesy of Service Engineering, Inc.



Courtesy of Wipotec

The FS(C)-series is comprised of single and dual filling and stopper-inserting machines, with or without the capping function, and is designed for 2ml to 100ml vials and offers an output of up to 200 vials per minute.

The compact in-line design features Allen Bradley components and is equipped with servo-motors. Format changeovers are highly automated using PLC-stored recipes per vial format.

Net Weight Filling: Optionally, load cells can be installed for net weight filling. The vial transport belt places the vials onto the load cells in such a fashion that the vials are free-standing without touching the transport belt.

The settling time of the load cells is 120ms, during which time the filling nozzles dive down for bottom-up filling.

Of the total fill, 90% will be dispensed at “high” speed and 10% at “low” speed. The fill volume and the speed are part of the recipe per vial.

The filling algorithm calculates the cut-off time during the low-speed liquid dispensing, with a repeatability factor of 0.0005 grams. The two load cells function independently from each other.

Filling, Stopper-Inserting and Capping

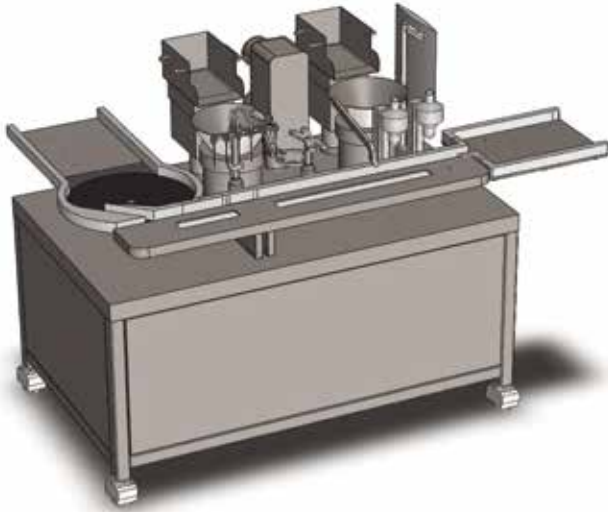

The FSC-2 is a 2-up intermittent-motion filling, stopper-inserting and capping machine designed for containers from 2ml to 100ml, with an output of up to 60 vials per minute.

The compact in-line design features two filling nozzles, a dual stopper-inserting station and two crimping heads for aluminum caps.

- All stainless steel construction
- Compact footprint: 152x91cm
- In-line or stand-alone executions
- Unique vial transport belt with positive vial control
- Up to 60 vials per minute
- Standard: Allen Bradley PLC and HMI/OIT
- Two independent peristaltic pumps
- Servo-motor controlled, bottom-up filling
- Optional pre- and post-gas flushing
- Stoppers and caps: 13mm and 20mm
- Automated, recipe-driven format changeover
- Compact stopper and cap feeders
- Bulk hoppers with level control
- Optional net weight filling
- Complete validation documents package available (FRS, DDS, FAT/SAT, IQ/OQ)
- Comprehensive equipment documentation with exploded 3-D assembly drawings
- O-RABS and C-RABS optional

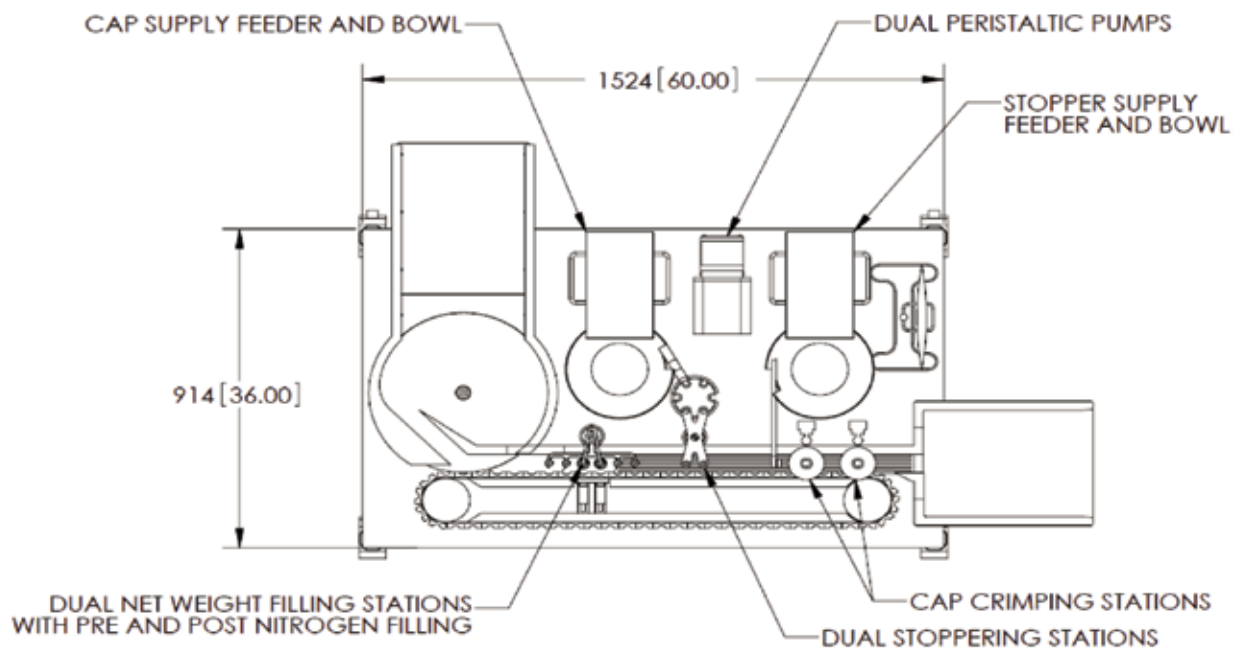



The AC-6 is a 6-head heavy duty in-line rotary capping machine for 2-100ml vials providing an output of up to 200 vials per minute.

GMP Design: All stainless steel construction, with tempered glass doors and windows. Stainless steel hinges with built-in safety switches. Sanitary, raised track conveyor for easy cleaning. No stopper, no cap pick up. Reject station available.

Compact Design: the electrical cabinet is located within the frame of the machine.

Versatile Design: 13, 20 and 32mm flip-off caps, PLC-assisted changeover.

Menu-Driven Operation through AB PLC and AB PanelView 1000 Plus.

Comprehensive machine documentation with exploded 3-D assembly drawings.

Complete validation documents package available (FRS, DDS, FAT/SAT, IQ/OQ).

External Vial Decontamination

SP Scientific's unique External Vial Decontamination System encapsulates the caps with a watertight seal.



Vials filled with potent drugs such as antibiotics, cytotoxics and cytostatics need to be cleaned before further processing.

SP's PennTech brand offers a unique solution to this requirement by enclosing the aluminum cap between two opposed belts. The seal that is created prevents the cleaning agent from entering the cap area, thereby eliminating potential future bacterial contamination.

Another advantage of sealing the cap is the application of pressurized water for cleaning the entire vial body, including the bottom.

Operation is menu-driven through the human machine interface (HMI). PLC-controlled servo motors automatically set the output rate, the vial height and the water/air flow per vial size. The changeover to a different cap or vial format is tool-less and can be accomplished within 15 minutes.



As a stand-alone system, the EVW can be equipped with a rotary infeed disk with loading platform. Machine above shown with an extended drying section for high throughput requirements.

External Vial Decontamination

Three models:

EVW-100: Fresh Water Rinsing, Compressed Air Drying

EVW-200: Recycled Water Rinsing, Fresh Water Rinsing, Compressed Air Drying

EVW-300: Recycled Water Rinsing with Detergent, Fresh Water Rinsing, Compressed Air Drying

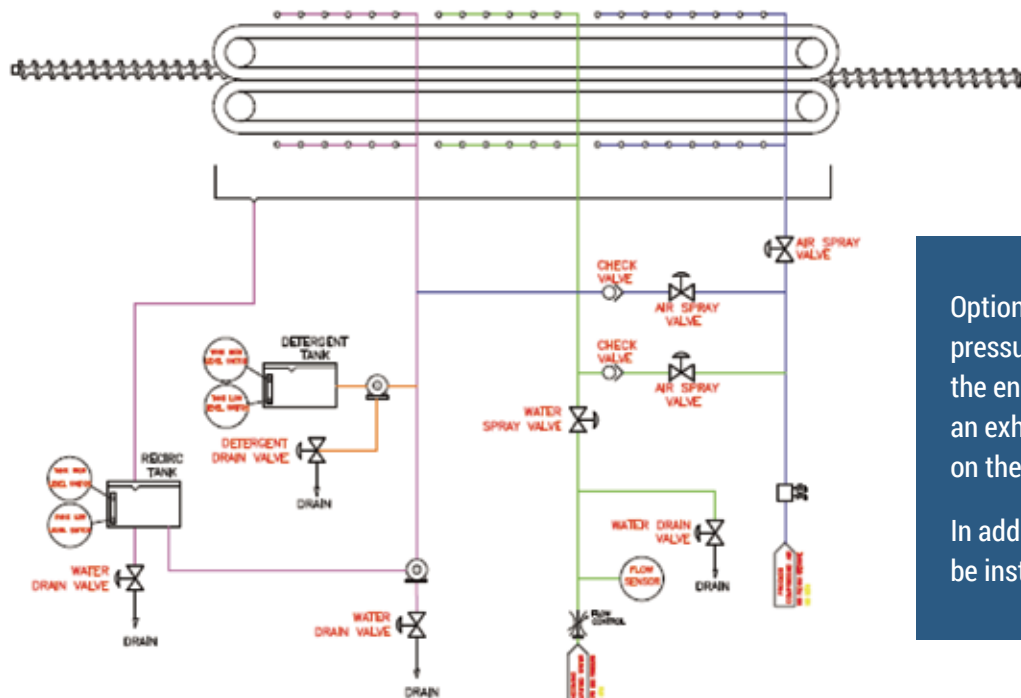

Optionally, negative pressure can be obtained in the enclosure by installing an exhaust with HEPA-filter on the top of the unit.

In addition, glove ports can be installed in the doors.

Typical PennTech Hallmarks:

Versatile: Designed for vials from 2-100ml.

Simplicity in design: Menu-driven operation, no alignments of spray nozzles, no format parts required for 13 and 20mm caps.

Simplicity in operation: Menu-driven changeover, automatic setting of output rate. Automatic height setting for all vial formats. Tool-less exchange of infeed and outfeed timing screws.

All stainless steel: Heavy duty construction with tempered glass windows and doors. Piping system and electrical cabinet are installed inside the frame of the machine, resulting in a small footprint and a clean installation.

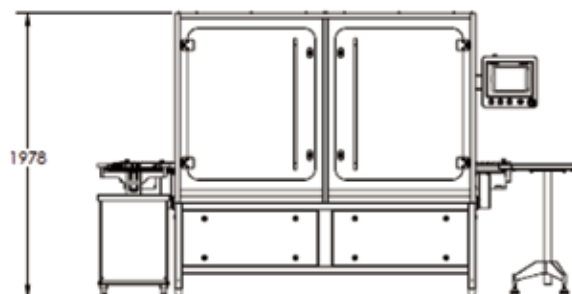
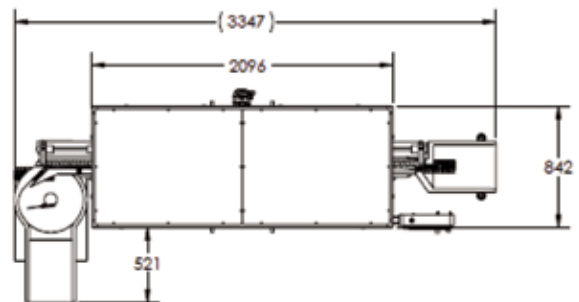

Trayloading

If vial collection is required, SP Scientific has the solution: customized trayloaders for your application and your tray format.

- Single trayloader up to 200 vials per minute
- Dual trayloader up to 400 vials per minute
- Vial range from 2-500ml vials/bottles
- No format/change parts required
- Menu-driven, PLC-assisted changeover
- Automatic nesting



- Optional automatic containment ring lowering system for freeze drying applications
- Optional camera inspection to ensure same cap color/format and vial configuration
- Consistency in trayloading, always the same number of vials per tray
- Non-stop loading, even when replacing a full tray

To integrate your aseptic filling line, you will need peripheral equipment:



Multi-lane accumulating table



Sanitary raised-track conveyor



Down-vial reject blocks



Through-the-wall conveyor



Rotary accumulating and transfer tables



Side-by-side conveyor transfer



Vial inverting table

Why SP Scientific – PennTech?

There are several compelling reasons to select SP Scientific's PennTech brand as your supplier for aseptic pharmaceutical equipment.

As an experienced and dynamic engineering company, SP has mastered the simplicity of machine design. Our PennTech brand has grown through two guiding design philosophies: "soft is better than hard" and "smaller is better than bigger." Thus, PennTech equipment uses motors instead of gears and belts instead of chains. The result is equipment with the smallest possible footprint that our customers can operate, maintain, and changeover quite easily.

Design simplicity also results in higher reliability and lower costs. Add the advantage to the US dollar versus the Euro exchange and you will see some real savings.

We provide recipe-driven, object-oriented programming for standard machine platforms that are easily adaptable to application-specific requirements.

SP Scientific's PennTech equipment documentation and validation protocols are among the best in the industry. Every machine comes with As-Built 3-D exploded assembly drawings, each with a bill of materials.

Choose our PennTech brand of equipment for your next machine replacement or complete line project and discover for yourself what so many others already have. We want to be your partner moving forward!

For more information on SP Scientific's Production Freeze Dryers, visit SPScientific.com/Hull



Contact information:

SP Scientific
103 Steamwhistle Drive
Warminster, Pennsylvania 18974 (USA)
Tel: 215.396.2200

For your nearest PennTech representative, go to SPScientific.com/PennTech