

PARTICIPATION RULES

PISCINA & WELLNESS BARCELONA 2023

CONTENTS

<ul style="list-style-type: none"> 1. NAME 2. NATURE 3. FREQUENCY 4. ORGANISATION 5. PLACE, DATE AND TIME HELD 6. INDUSTRIES 7. PARTICIPATION 8. PARTICIPATION FEES 9. LAYOUT AND ALLOCATION OF SPACES 10. PARTICIPATION CONTRACT 11. PAYMENT TERMS AND CONDITIONS 12. SERVIFIRA – CONTRACTING SERVICES 	<ul style="list-style-type: none"> 13. CHANGE OF LOCATION 14. CHANGE OF SURFACE AREA 15. CANCELLATION OF PARTICIPATION BY THE EXHIBITOR 16. FORCE MAJEURE 17. EVENT DRESS CODE 18. HEALTH PROTECTION MEASURES AT THE EVENT 19. CONTRACTUAL DOCUMENTS AND ACCEPTANCE OF THE PARTICIPATION RULES
---	---

ANNEX

1. Name

PISCINA & WELLNESS BARCELONA 2023 Piscina & Wellness Barcelona International Trade Fair

Assembly: from 22nd to 25th November 2023 from 8:00 am to 8:00 pm
 26th November from 8:00 am to midnight

2. Nature

Professional.

Breakdown: Goods can be taken away by hand on Thursday 30th November 2023 from 5:00 pm to 10:00 pm
 From 1st to 3rd December 2023, from 8.00 am to 8.00 pm

3. Frequency

Biennial

Fira Barcelona reserves the right to change the assembly times if deemed necessary.

4. Organization

Fira de Barcelona
 Av. Reina M^a Cristina, s/n - 08004 - Barcelona
 Tel.: 902 233 200/+34 93 233 20 00
 Email: piscinawellness@firabarcelona.com
 Website: www.piscinawellness.com

6. Industries

1. Prefabricated swimming pool vessels
2. Pool constructors
3. Wellness (spas, hydrotherapy baths, solariums, saunas and other equipment)
4. Cleaning
5. Physical-chemical water treatment
6. Lighting, public address system and acoustics
7. Air conditioning
8. Aquatic facilities (design, construction, materials and equipment)
9. Coating, crowning and ornamentation
10. Roofs
11. Security equipment (barriers, alarms and other equipment)
12. Exterior and interior furniture and complementary accessories
13. Software for the design and management of swimming pools and facilities
14. Purification (filters and pumps)
15. Control, measurement and handling equipment
16. Pool accessories (white goods)
17. Installation accessories

5. Location, dates and schedule of the event

Location: Gran Via Venue - Halls 1 and 2
 Dates: 27th to 30th November 2023

Exhibitors:	27th to 29th November from 9:00 am to 8:00 pm 30th November from 9:00 am to 5:00 pm
Visitors:	27th to 29th November from 10:00 am to 7:00 pm 30th November from 10:00 am to 4:00 pm

18. Associations, technical press and service companies
19. Sports/recreational installations
20. Security equipment (barriers, alarms and other equipment)
21. Fitness
22. Solar protection
23. Indoor and outdoor flooring

The organisers reserve the right to immediately withdraw any products that do not fit in with any of the industries represented at the Fair.

7. Participation

Once your company has expressed an interest in participating in the Fair, an account executive will contact you to send you the participation proposal that best suits your needs.

Once the proposal has been accepted, the relevant Participation Contract must be signed electronically and sent by the Organiser by email.

In any event, in order to take part in the fair, you will have to pay the registration fee of €495 per customer and per fair for the opening and processing of the dossier, Wi-Fi, exhibitor passes, inclusion in the online catalogue, invitations and mandatory insurance.

You will not be able to register for the Show if you owe existing debts to Fira Barcelona.

8. Participation Fees

8.1 REGISTRATION FEES

The dossier opening and processing fee is €495 per client.

The registration rights include the opening and processing of the dossier, Wi-Fi, exhibitor passes, insertion in the online catalogue, invitations and mandatory insurance.

Prices do not include VAT.

8.2. WAYS OF PARTICIPATING

8.2.1 SPACE RENTAL

The fees for open spaces are as follows:

- 20 to 40 m²..... €198.00 /m²
- 41 to 80 m²..... €195.00 /m²
- 81 to 100 m²..... €190.00 /m²
- 101 to 140 m²..... €187.00 €/m²
- 141 to 200 m²..... €185.00 €/m²
- 201 to 300 m²..... €177.00 €/m²
- Over 300 m²..... €165.00 /m²

Not including registration fees.
 Prices do not include VAT.

Minimum space to be contracted in this format: 20 m²

8.2.2 GROWING PACK

Turnkey participation category that includes the space rental, stand rental and the additional services indicated in the participation application.

The fees for stand packages are as follows:

- Economy Package S (from 20 m²).....
 Additional €5,420 + €260m²
- Premium Package S (from 20 m²).....
 Additional €5,760 + €275m²
- Economy Package M (from 40 m²).....
 Additional €9,880 + €236m²
- Premium Package M (from 32 m²).....
 Additional €11,808 + €337m²
- Premium Package L (from 48 m²).....
 Additional €17,760 + €352m²

Not including registration fees.
 Prices do not include VAT.

Wellness / Outdoor living Growing Package

Turnkey form of participation for Wellness accessory companies:

- Service companies (software, management, engineering, architecture, etc.).
- Auxiliary installations (apparatology, aromatherapy, etc.).
- Accessories (candles, ornamentation, cosmetics, etc.).

This category includes the space rental, stand rental and the additional services indicated in the participation application.

The fee for the Wellness stand package is as follows:

- Wellness / Outdoor living Package (6 m²).... €1,890

Not including registration fees.
 Prices do not include VAT.

8.2.3 PARTNERSHIP

Form of participation that includes different visibility options, networking and extra services that are indicated in the participation application.

The partnership fees are as follows:

- Platinum Partner (from 100 m²)..... €23,200
- Gold Partner (from 100 m²)..... €7,300
- Silver Partner (from 60 m²)..... €3,900
- Bronze Partner..... €1,950
- Wellness Partner €1,800
- Outdoor Living Partner €1,500
- Innovation Partner €4,500
- Sustainability Partner €3,500

Prices do not include VAT.

8.3 CO-EXHIBITORS

Exhibiting companies can authorise other companies to participate in their stands as co-exhibitors by paying €495 in registration fees and filling out the form provided by the fair, in which the rights of co-exhibitors are outlined.

Prices do not include VAT.

8.4 STAND ASSEMBLY SERVICES

The company hired to carry out the assembly of the stand must pay Fira Barcelona the fees described in the Online Services Catalogue for stand assembly services before beginning assembly. These fees are set according to the following types of assembly:

Carpet or wooden floor..... €2.60/m²
– Modular Stand..... €5.30/m²
– Design Stand..... €8.20/m²

Prices do not include VAT.

If the stand is booked through SERVIFIRA, they will pay the stand assembly contractor fees.

All exhibitors/fitters/decorating companies that have outstanding balances with Fira Barcelona, regardless of which Event/Edition/Act the debt involves, shall not be allowed to start assembling the stand.

Any personnel entering the Venue who are not employed by the exhibitor must provide the Customer Services Department with their full name and ID/Passport for issue of their assembly ID passes.

The rules for assembling the stands can be viewed at <http://www.firabarcelona.com/normativa-de-participacio>.

8.5 WASTE MANAGEMENT

All the decorating companies are responsible for the removal of waste during the assembly of their stands and must leave their space clean and empty once the disassembly period has ended. Exhibitors may contract waste and garbage removal services via the online services catalogue.

In the event that waste of whatever nature is left behind upon expiry of the dismantling period, the exhibitor will incur a fine of up to €50 per m² occupied.

8.6 MANDATORY INSURANCE

Multi-Risk Material Damage and Civil Liability Insurance is obligatory and all Exhibitors adhere to the insurance policy contracted by FIRA BARCELONA for all exhibitors by their participation in the trade show. That policy includes the following cover for Material Damage and Civil Liability insurance.

8.6.1. MATERIAL DAMAGE INSURANCE COVERAGE

- This includes physical damage to ensured goods that are on display as a result of one of the covered risks, with the limit of the sum insured at €20,000.00 for a First Risk per Exhibitor.
- This includes Attendance Costs, understood as duly justified costs of travel, advertising, hotels, fees for staff involved in attending to the public and the maintenance of the stand paid by the Exhibitor, with the limit of the sum insured at €10,000.00 for a First Risk per Exhibitor.

These expenses will be compensable when participation is definitively cancelled because of an accident covered by Material Damage, before the start of participation.

Risks Covered:

- Fire, Lightning and Explosion
- Extensive Risks: Vandalism, rain, wind, hail or snow, water damage, smoke damage, terrestrial vehicle impact, falling aeroplanes or spacecraft, sound waves, accidental leakage from automatic fire suppression systems.
- Complementary Guarantees: measures adopted by the authorities, salvage and removal of rubble, filling of fire extinguishing equipment, replacement of files and fire extinguishing expenses.
- Additional Guarantees: Goods exposed to the elements, breakage of windows and glass and electrical damage to electrical or electronic equipment.
- Disaster Risks: Flood earthquake, atypical cyclonic storms, hurricane, tsunami, volcanic eruption, terrorism, civil unrest, actions by armed forces and security forces in times of peace.

Excesses:

- The exhibitor accepts an excess of €300 per claim involving Material Damage and €300 per claim involving Attendance Costs.
- Damage and loss resulting from burglary, robbery, theft and employee disloyalty are excluded from the coverage.

8.6.2. CIVIL LIABILITY INSURANCE COVERAGE

Includes all claims derived from material damage and/or bodily harm and their consequences to third parties, for which the Exhibitor may hold civil liability.

FIRA BARCELONA holds the status of a third party in relation to the Exhibitor, and as a result coverage includes material damage and/or bodily harm and any consequences thereof to FIRA BARCELONA, for which the Exhibitor is assigned civil liability.

It includes any claims resulting from bodily harm as a result of workplace accidents suffered by the employees of the Exhibitor, for which the Exhibitor is held civilly liable.

It includes any demands resulting from bodily harm because of food poisoning, for which the Exhibitor is assigned civil liability.

A limit of €300,000.00 is established per claim and Exhibitor, with a sub-limit of €150,000.00 per victim in case of workplace accident.

There is an overall limit per claim and per trade show of €1,500,000.00 for all Exhibitors.

Excesses: The Exhibitor accepts an excess of €300 per claim.

8.6.3. LEGAL PROVISIONS

Processing Incidents

Should an incident occur, the Exhibitor must contact the Head of Services for the Hall, who will help them and will handle the incident together with our Risk Control Service.

In the event of vandalism, the reporting of the incident must be accompanied with the original report to the police, which must have been presented within 24 hours of the occurrence of the said incident.

Excesses

Any excess will be covered exclusively by the Exhibitor, with FIRA BARCELONA having complete indemnity.

Main Excluded Goods

- Goods that are not part of the exhibition, except for goods belonging to employees.
- Goods that are not located within the premises of the trade show venue.
- Money, deeds, jewels, works of art and objects of value.

Premiums and Coverage

The indicated coverage is subject to change according to the result of annual renewals or modifications which may be made to the terms and conditions of the policy.

Existence of other insurance policies

This policy will be in excess or defect of any policy that each Exhibitor may have at the time of the incident.

Documentation

Exhibitors may ask FIRA BARCELONA for an Insurance Certificate certifying the premiums and coverage of the policy, provided by the insurance company.

8.7. ACCESS CONTROL (GRAN VIA VENUE)

In order to insure the security of the facilities and to regulate correct mobility within the Gran Via venue by controlling vehicle access to the premises, all vehicles will be charged a fee to access the premises according to the type of vehicle and the time spent on the premises.

These fees and the conditions for accessing the facilities are available to users prior to access.

8.8 VAT

VAT will be added to all prices indicated, according to European Regulations. In accordance with the aforementioned regulations, starting in 2011 the new rules on the localisation of services will be applied, and as a result all services between businesses (B2B) related to fairs as well as any complementary services shall be subject to tax where the recipient is based.

9. Layout and Allocation of Spaces

The distribution and allocation of spaces is the exclusive responsibility of Fira Barcelona. Starting on 1 October 2022, the process of distributing and allocating spaces among the companies who have asked to participate will begin. This allocation will be based on considerations of a technical and/or sectoral nature related to the exhibition as a whole and the materials to be exhibited, although an effort will be made to include considerations such as the number of years the company has attended the fair, the date on which they applied and the size of the stand requested.

10. Participation Contract

The Organiser will send the Participation Contract to participating companies. There are two types of contract the client may request:

- a) Contracts with a specific location: In which the proposed location and m² allocated will be indicated on a rental basis.
- b) Contracts without a specific location: Reference will only be made to the m² allocated on a rental basis, or the type of stand package requested by the client.

The signing of this Contract entails the acknowledgement and acceptance of the space, of the assigned location, the Rules of Participation of the Trade Show and Fira Barcelona's Regulations on Participation by Exhibitors. The Participation Contract is solely valid for the Company listed on the Registration and for a single edition of the Fair.

In either of the two types of contract, 3 invoices will be issued with the following dates for payment:

- 1st due date: On the date of the invoice, for 10% of the participation fee.
- 2nd due date: Within 135 days of the date of assembly, for the amount corresponding to 25% of the cost of participation.
- 3rd due date: Within 45 days of the date of assembly, for the amount corresponding to 65% of the cost of participation.

If the contract is signed within a period less than those mentioned above, the payments will be regrouped into 1 or 2 invoices (depending on when the contract is signed), for the amount corresponding to 100% of the cost of participation and services. In any event, all invoices must have been paid in full before the start of stand assembly for the trade show.

In contracts without a specific location, the issuance of the participation contract will automatically generate the invoice for the registration fees. Once the contract has been signed, the first invoice for participation will be generated.

In contracts which include a specific location, the space will be allocated as soon as the invoice for the registration fees has been paid. Once the registration fees have been paid, the Participation Contract will be generated by the Organisation, with the specific location and the m² allocated, as well as the type of stand package selected and any additional services contracted, where applicable. Once the contract has been signed, the first invoice for participation fees will be issued.

11. Payment Terms and Conditions

All the invoices must be paid to Fira de Barcelona – PISCINA & WELLNESS BARCELONA 2023 in one of the following ways:

- Direct debit (only for bank accounts in Spain). If this option is selected, all invoices issued by Fira Barcelona for any fair will be processed using this means of payment.
- Cash or credit card, paid at the Fira de Barcelona Customer Service offices.
- Bank transfer to any of the following bank accounts.

Caixabank S.A.

IBAN: ES49 2100 0927 5602 0001 7660
BIC/SWIFT: CAIXESBBXXX

BBVA

IBAN: ES19 0182 6035 4302 0160 9244
BIC/SWIFT: BBVAESMMXXX

Banc Sabadell

IBAN: ES19 0081 5084 04000129 0030
BIC/SWIFT: BSABESBB

IMPORTANT:

For your payment to be registered correctly, you must quote the **client code and the invoice number**, which appear on the invoices, on your transfer or banker's/certified cheque, made out to FIRA INTERNACIONAL DE BARCELONA.

12. Servifira Contracting services

Servifira (www.servifira.com) makes the Online Fira Store Services Catalogue available at <https://store.firabarcelona.com/k046023> and on the trade fair website. In the Fira Store exhibitors will be able to contract all the services they need to participate in the Trade Show:

- Supplies: Internet, electricity, compressed air, anchor points...
- Decoration: furniture, landscaping, carpeting...
- Visual impact: graphic services, advertising, merchandising...
- Audiovisuals
- Personnel: hosts/hostesses, security, translators and interpreters...
- Cleaning
- In-stand catering

You can also book a custom-designed stand through www.buildupfira.com, the stand design and construction department, through which the exhibiting company can hire any service they need for the preparation of their stands: audiovisuals, catering, hosts/hostesses, rigging, etc.

Telephone support: (+34) 93.233.20.00
Email: piscina.servifira@firabarcelona.com

Timings: Exhibitors are advised to contract the services well in advance. **If you place orders before 16th November, you can**

ensure the availability of the services and obtain discounts of up to 30%.

The general delivery of the services will be carried out during the whole period of assembly (the furniture will be delivered on the last two days of assembly). In the event that the exhibiting company requires special delivery conditions, it must contact ServiFira for these purposes.

Handling of incidents during the assembly: The exhibiting company should contact the telephone number 932 332 000, with the free telephone numbers for exhibitors located in the halls near the office of the hall manager of the fair or in the customer service department.

All the material of the stand is on hire, so it must be returned in the same condition in which it was delivered. All graphics or signs installed by the exhibitor must be removed on the last day of the trade show days. In the event that they have not been withdrawn, the organisation reserves the right to bill the exhibitor for any removal costs.

13. Exhibitor's Area

Through the **Exhibitor's Area**, exhibitors can also:

- View their invoices
- Check the trade show policies of participation
- Check the technical sheet of their space
- Manage passes and invitations
- Manage all the requirements regarding participation

Private access to the Exhibitor's Area is through the use of the passwords sent by email to the exhibiting company's contact person as specified on the trade show participation form.

Exhibiting companies must ensure that they provide their assembly company with all the information relating to their stand (stand technical sheet, and Fira de Barcelona's technical regulations relating to the corresponding venue).

14. Modification of location

In the interests of the event, Fira Barcelona reserves the right to modify the space reserved by the exhibitor within the venue of the fair, without the exhibitor being able to demand any sort of refund in exchange. The exchange, transfer or sublease of the rented space to third parties is expressly prohibited.

If, for any reason beyond the Organiser's control, it is unable to provide the exhibitor with the reserved space and another of similar characteristics or if a smaller size is allocated within the same trade show venue, the exhibitor will be refunded the amount corresponding to the difference between what was paid for the reserved space and the cost of the space finally allocated, without the exhibitor being entitled to any compensation, and

therefore, waiving the right to make any claim in this regard. For this purpose, all parties must sign the corresponding Annex to the Participation Contract.

If, for any reason beyond Fira Barcelona's control, including the existence of construction or maintenance activities within the fairground in which the event is to take place, it proves impossible to hold the event at any of the Halls or Halls of the venue, Fira Barcelona can modify the location of the event, transferring it to its other fairgrounds with any participation contracts signed before this date no longer being in effect and considered terminated.

Notwithstanding the above, Fira Barcelona will maintain all customers as exhibitors except if they state in writing that they do not wish to participate in the event in its new location. Any amount paid by continuing exhibitors until that time will be applied to the new contracts made.

If written notice is received from the exhibitor stating their intention not to participate in the event at its new location, Fira Barcelona will proceed to refund the amounts paid to date by the exhibitor according to the participation contract, without the exhibitor being entitled to any sort of compensation as a result, waiving the right therefore, to any claims in this regard. The participation contract between the parties will be automatically cancelled as soon as the notification from the exhibitor is received.

15. Change of surface area

Should the exhibitor ask for a reduction in space, they will lose their right to the entire previously contracted space, although they may request a new location within the available spaces. Should the exhibitor request an increase in space, Fira Barcelona will fulfil their request providing that additional space is still available. In either case, a new contract for the space must be drawn up between the Organisation and the exhibitor. In the event that no additional space is available, the existing contract may not be changed.

16. Cancellation of Participation by the Exhibitor

Exhibitors may cancel their participation in PISCINA & WELLNESS BARCELONA 2023 in writing or by any other reliable means that allows for the certification of the delivery and receipt of the notification. Once the notification has been verified, the Organiser will cancel the Exhibitor's account and issue a detailed account of the invoices for participation and services.

a) If the cancellation takes place before **10.07.2023** (135 days before assembly) any payments made will be refunded to the Exhibitor.

b) If participation is cancelled between **11.07.2023** (-134 days before assembly) and **08.10.2023** (45 days before assembly), the Exhibitor will be required to pay 100% of outstanding invoiced amounts by way of sanction for cancellation of its participation.

c) If the cancellation takes places before **7.10.2023** (44 days

before assembly) the penalty will be 100% of the final settlement.

The fee corresponding to the Registration Fee will not be refunded under any circumstances.

Should the Exhibitor fail to make any payment before the start of assembly or should it fail to occupy the space booked, the Organiser may transfer the space or stand to a third party and will not be obliged to pay any compensation or refund any fees paid for the use of the space.

17. Force Majeure

Fira de Barcelona reserves the right to reduce or extend the duration of a certain Fair, or to postpone the event or its assembly or dismantling date, provided that it is forced to do so due to special circumstances or a force majeure. Such circumstances will not entitle exhibitors to terminate their contracts or to claim damages.

If, as a result of COVID-19 or any of the limitations generated by it, it becomes impossible to hold the Trade Show on its scheduled dates, in the event that the exhibitor does not wish to maintain their participation on the new dates, they shall be entitled to a refund of the amount paid for their participation, including the registration fees. With regards to the contracted services, and provided that the exhibitor does not wish to continue contracting them for the new dates of the event, the Organiser shall return the amount charged for this concept, after deduction of any duly justified costs incurred to the exhibitor. Under no circumstances shall the exhibitor be entitled to claim any compensation for damages.

18. Event Dress Code

The personnel representing the exhibiting companies in the stands must be dressed appropriately for the duties they are carrying out. Costumes or complementary articles which involve the objectification of the person or that could offend other exhibitors or attendees on ethnic, religious, sexual, political or social grounds are not permitted.

It is the exhibitors responsibility to ensure that all personnel present in their stand (regardless of whether they are their direct employees or those employed by their suppliers) are dressed in a professional and appropriate way. In the event of any breach of this rule, and with the decision adopted by the Organiser being final, the staff member in question will be required to leave the venue.

19. Health Protection Measures at the Event

In accordance with the recommendations and standards established by WHO and/or national authorities for the control of

diseases with risk of contagion, including epidemics and/or pandemics, exhibitors undertake to strictly comply with the protocols implemented by Fira de Barcelona at all times to guarantee health and safety at its events. These protocols are available on the event's website.

20. Contractual Documents And Acceptance Of The Participation Rules

These Participation Rules are part of the contractual terms and conditions. Any circumstances not expressly provided for in these Rules of Participation will be covered by Fira de Barcelona's General Regulations governing Participation for Exhibitors, to which all Exhibitors expressly submit. These regulations can be viewed at www.firabarcelona.com

In the event of contradictions or discrepancies between these two documents, whatever is established in these Rules of Participation shall apply.

ANNEX:

1.- Rules for Construction

The allocation of a space in its “space-only” format does not include the assembly of any kind of stand or structure.

It is mandatory for all the exhibitors to build a stand in their exhibition spaces. On no account may the walls of neighbouring exhibitors be used for stand assembly purposes.

Inner enclosures:

The construction of completely enclosed stands is not permitted. The exhibitors must not obstruct the visibility of adjoining stands. Up to a maximum of 50% of each open side of the assigned space may be enclosed.

Height rules:

The maximum permitted height is:

- 3 metres around the perimeter of the stand.
- 5 metres inside the stand, as long as the walls are set back at least 1 metre from the perimeter.

Suspended elements:

The structures hanging from the ceilings of the pavilion must abide by the height regulations, according to the specific location of the exhibition area in which the stand is located. A truss with lighting can be placed on the perimeter of the space at a maximum height of 6 metres, provided that advertising is not suspended from it. If you wish to suspend elements from the truss, the height regulations must be abided by and therefore not exceed 5 metres from the floor.

All the exhibitors with freely designed stands, regardless of the size of the space, must send a scale copy of the construction plan (both the floor and the sides with heights) to operations.piscina@firabarcelona.com by 03/11/2023. The department of operations will validate it and send the approval of the project to the exhibitor.

Construction of complex structures in the halls and open-air:

Fira de Barcelona can authorise the construction of a complex structure according to the regulations established by the event organiser and in the sectors where the roof height and hall structure so permit.

A complex structure is understood to be any construction that requires the intervention of a competent technician related to the design, calculation or certification of its final strength, or if a significant risk assessment is required.

Complex structures are classified in the following manner:

Modular stands or structures more than 5 metres in height. These must have a minimum of three perpendicular support plans over their entire height. Cases with $H > 5$, in the event of exhibiting **pools in a vertical position** (with the bottom of the pool perpendicular to the floor of the hall) that are over **5.00 metres** in height, will be regarded as complex structures.

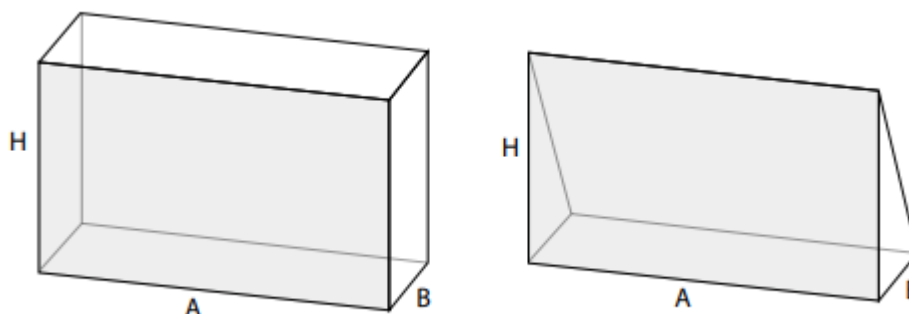

- Similar one-off structures up to 4 metres high. These structures are considered in totem-type constructions, isolated or corporeal partitions or any structure that doesn't have a minimum of three perpendicular support planes over their entire height.
- $H > 4\text{m}$ and $B/H < 0.4$ (slenderness coefficient: relationship between dimension B and the height of element H).

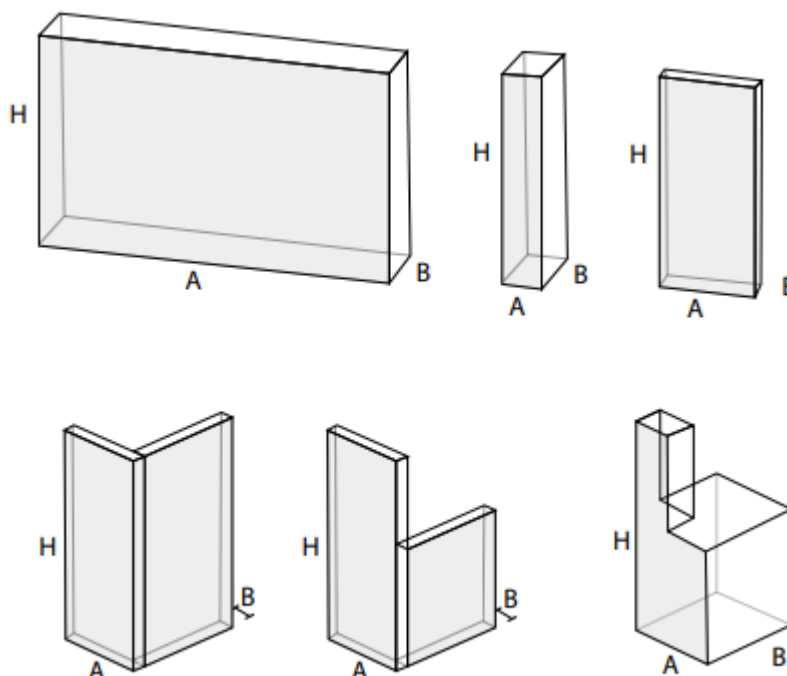

In order for the assembly of these structures to be authorised, it will be necessary to provide the fair's Operations Department with a **technical project endorsed** by a professional association to certify the resistance of the substructures that maintain the pools in a vertical position and the capability of the whole structure to withstand horizontal forces. You can view the content of the project in the Complex Structures section of these technical regulations.

Before the start of the event a competent technician will have to issue a **certificate of soundness endorsed** by a professional association to guarantee the proper assembly of the structure.

It is advisable to focus the construction of your stand on recycled material and/or reused materials to align it with the event, for which there is an initiative, Towards Zero Impact, to reduce waste, save resources and promote sustainability. Every effort should be made to make sustainable, accessible and low-carbon choices in its design, construction and execution.

2- Rules for use of the Wi-Fi service

Fira de Barcelona has one of the largest Wi-Fi infrastructures in the world, with more than 1,200 aeriels spread over the entire venue. This infrastructure will be available at no cost to both exhibitors and visitors. For everyone's benefit, all Wi-Fi connections must be managed by Fira de Barcelona. Fira will use scanners to detect other Wi-Fi networks outside the venue facilities and enforce their uninstallation.

3-Recommendations for exhibitors:

- Exhibitors and their assembly companies are prohibited from installing and using Wi-Fi networks other than those of the venue.
- The use of any other equipment that operates with the 2.4GHz or 5GHz frequencies, such as wireless audio and light devices, is not allowed. If its use is necessary, please contact our IT and network department: internet@firabarcelona.com.
- If the internet connection is crucial for the product demonstration or work at the stand, it is advisable to hire cable internet. If this is not possible, we recommend only using devices that require 5 GHz internet.
- If you have any queries or special needs, we advise you to contact Fira de Barcelona's IT and network department prior to the event: internet@firabarcelona.com.
-

4- Commercial Transactions (Sales Regulations)

The direct sale of articles to be withdrawn from stands throughout the course of the fair will not be permitted. Any exceptions to what is stated above will be subject to the provisions set out in the Spanish Law on Commerce, Services and Fairs and its Regulations.

5.- Regulations on Prize Draws and Games of chance

Any prize draws or contests exhibitors wish to hold require prior authorisation by the Organiser.

In any event, any prize draw, lottery or game of chance requires prior authorisation from the Directorate-General for Gambling and Performances and is subject to the Regulations on prize draws, lotteries and games of chance and any other applicable law.